

# TECH NOTE

No. 003

Original Date: 12/05/93

Revision No.: 001

Rev. Date: 07/11/96

Author: John Frank

Cessna Pilots Association <sup>TM</sup>



P.O. Box 5817, Santa Maria, CA 93456  
Phone 805/922-2580 800/343-6416 Fax 805/922-7249

Internet Web Site: [www.cessna.org](http://www.cessna.org)

[cpa@cessna.org](mailto:cpa@cessna.org)

© Copyright 2000, Cessna Pilots Association, Inc.

## Uneven Fuel Feeding in Single Engine Cessnas

One of the problems that the Cessna Pilots Association is most often consulted about has to do with the fuel feeding unevenly from the tanks when the fuel selector is in the 'BOTH' position. This problem is most common on 150, 172

pulling fuel down the fuel feed lines to the carburetor.

The air pressure in the tanks will also be a force acting to push fuel down the fuel feed lines. Ideally in the Cessna single engine aircraft this pressure will be slightly above ambient, that is the pressure of the outside air. This air pressure in the tank is often referred to as 'head pressure', meaning the pressure above the fuel level that is pushing the fuel down the fuel feed lines. The actual head pressure is important, a slight amount of pressure is necessary to hold fuel bladders in place and too much pressure can push fuel around and cause uneven fuel feeding. Also very important is the relationship of the head pressure to ambient air pressure. In regards to even fuel feeding, the head pressure in both tanks must be equal for the tanks to flow at the same rate. If the tanks do not have the same

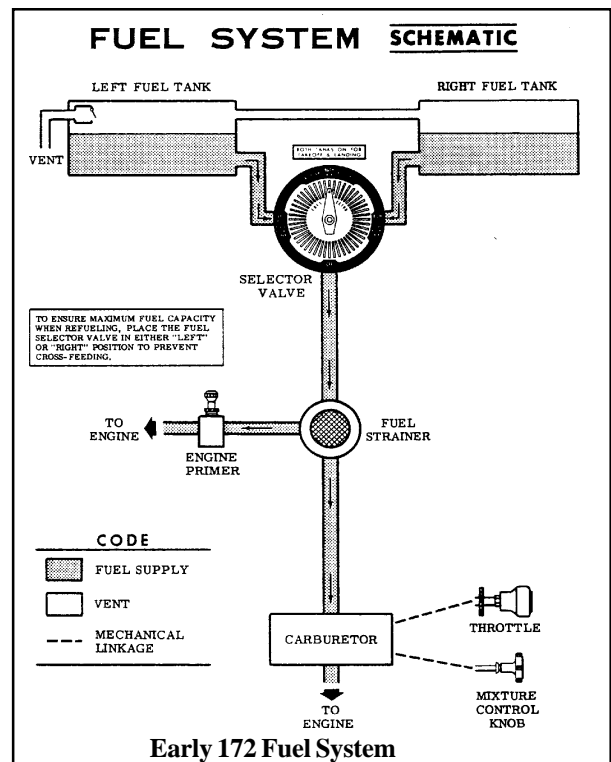
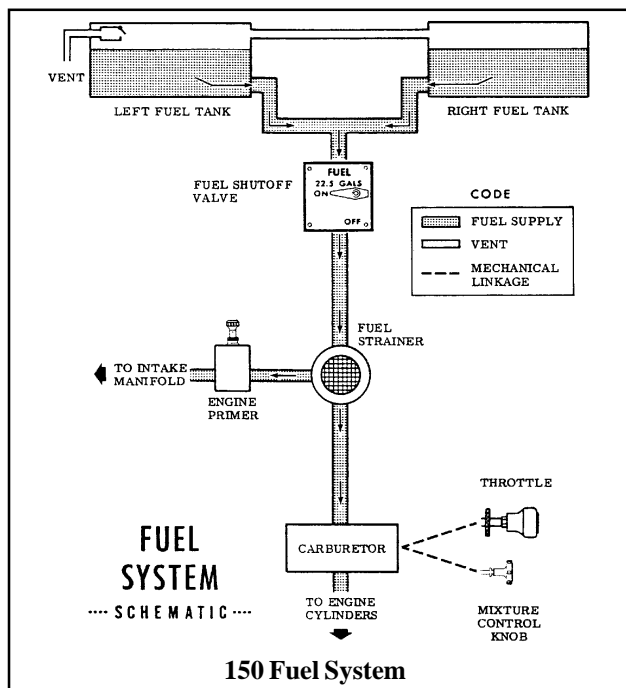

and pre-1979 182 series aircraft with a single fuel tank vent positioned behind the left lift strut, however the problem has been reported on just about every Cessna single engine model that has a "BOTH" position on the fuel selector. It is certainly very disconcerting to be flying along and watch your left fuel gauge going down while the right fuel gauge continues to indicate full. The funny thing about this situation is that while only the left gauge is showing fuel usage, the engine may very well be using fuel from the right tank!

To understand what causes uneven fuel feeding we have to go through some of the basics of the fuel system. First we need to know that in most of the single engine Cessnas with carburetted engines two forces cause the fuel to move from the fuel tank to the engine. One of these forces is one that everyone is aware of; Gravity. In fact the fuel systems used in these high wing aircraft are often referred to as 'Gravity Feed Fuel Systems'. With fuel tanks mounted in the wings high above the height of the engine and carburetor, gravity will be

head pressure then the tank with the lower head pressure will flow the slowest.

As fuel is used from a fuel tank it must be replaced by something. If we didn't replace the fuel with something then as the fuel is used there would be nothing to occupy



# TECH NOTE

the space that the fuel used once occupied and, given that the fuel system was tight, the head pressure in the tank would be less than the ambient air pressure outside. If this difference between the outside air pressure and the tank head pressure became too great, several not very desirable things could happen. This reduced head pressure could cause fuel not to flow down the fuel feed line in sufficient quantity to meet the engine's demand. This could cause the engine to run rough or stop. If the aircraft has a rubber bladder as the fuel tank the bottom of the tank can be sucked up which will cause the fuel tank gauge sending unit, which is being lifted by the rising bottom of the tank, to indicate erroneously high amounts. In a really severe case of pressure differential with the inside of the tank being lower in pressure than the outside, total tank collapse could occur. This could occur not just with the bladder type tanks but also with the drop in tanks used on the 150, 152, and 172 and the integral tanks used on late model 182s and the 210. On the aircraft with integral tanks this means that a section of the wing could literally implode!

To prevent dire consequences such as listed above, the fuel tanks are vented to the outside and air is allowed to replace fuel as it is used. On most single engine Cessnas with carburetted engines a single "L" shaped vent tube that is located behind the left lift strut is used. This vent tube is connected by hosing and tubing to the outboard portion of the left fuel tank. As fuel is used from the left tank it is replaced by air from the outside. This takes care of the venting of the left tank. But how about the right tank?

It was in venting the right tank that Cessna engineered a novel but, as it turned out, not very satisfactory solution. Knowing that the right tank had to be vented and also knowing that the head pressure in the right tank had to be equal to the head pressure in the left tank, Cessna thought they could accomplish both tasks at the same time. The engineers reasoned that if they connected the top of the left

tank to the top of the right tank they would be venting the right tank with air from the left tank and the pressures would be equal. A good idea on paper perhaps but not such a good one in practice.

What the engineers hadn't given proper consideration to was wing dihedral and fuel slosh. Cessna wing tanks can be very long and shallow, on the 182 Skylane the long range tank is only 8" deep but is 7 feet long! This shallow, wide shape makes the fuel feed very sensitive to tank, or head, pressure. Wing dihedral places the outboard portion of the fuel tank above the inboard portion, sometimes by as much as several inches. This means that when the tanks are full the vent interconnect line is below the fuel level and is full of fuel. When air enters the left tank to replace fuel being used, the pressure pushes fuel from the left tank through the vent interconnect into the right tank, replacing any fuel that has been used from the right tank. In this manner the right tank

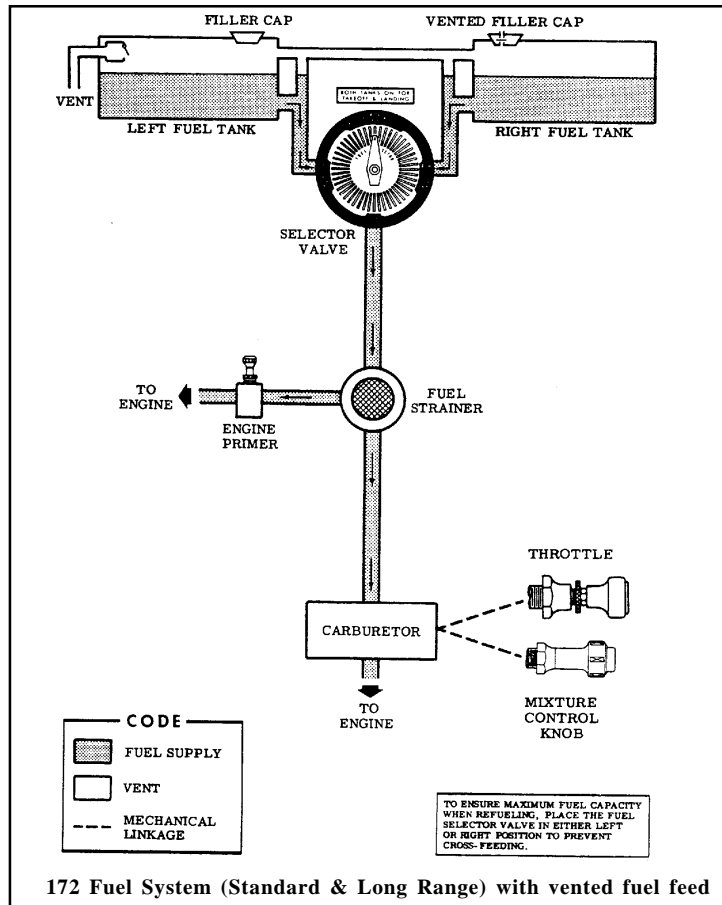

can remain full even while fuel is being used from it while the left tank goes down even faster than fuel is being fed to the engine from it! This transferring of fuel from the left tank to the right tank will continue until the fuel level in the left tank drops below the height of the vent interconnect line. In fact the fuel transfer can continue for awhile even after the fuel level in the left tank has dropped below the height of the vent interconnect line because motion in flight will tend to slosh some fuel into the vent interconnect line from time to time and this fuel will be pushed/pulled into the right tank. It is only when the fuel level in the left tank is so low, usually around half tank level, that none of the remaining fuel in the left tank can make it's way to the vent interconnect line that the fuel passage from the left tank to the right tank will stop.

One good thing to note, and it is an important one, is that this is not really a problem of uneven fuel quantities being fed to the engine. Actually the engine is receiving approximately the same amount of fuel from each tank at any given time with the fuel selector in the 'BOTH' position. It appears



# TECH NOTE

to be uneven fuel feeding on the gauges because the fuel being used from the right tank is being replaced by fuel from the left tank. This means that there will not be fuel flow interruption to the engine even if the left tank were to go dry with the fuel selector in the 'BOTH' position.

There is a misconception going around concerning the

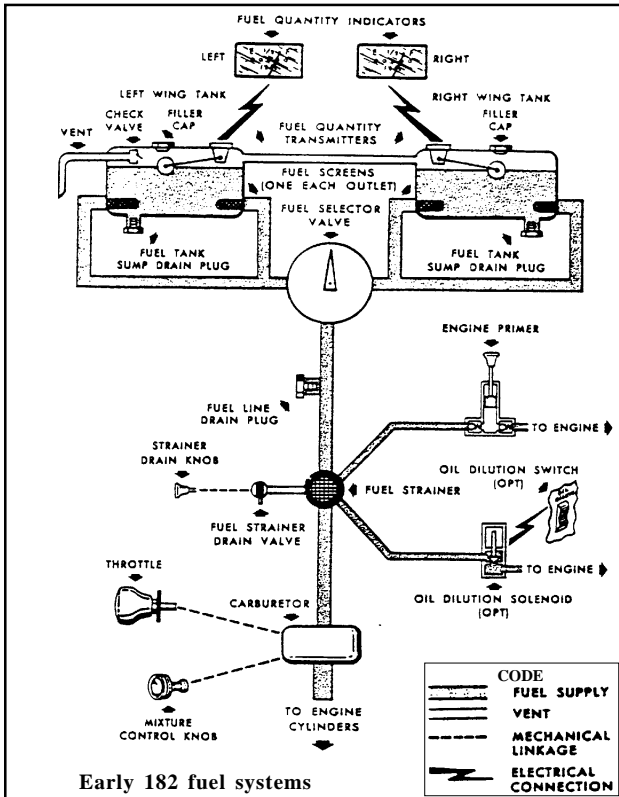

fuel caps and the vents in them. In 1979 AD 79-10-14 (which superseded 78-26-09) was issued that required the installation of vented fuel caps on most single engine Cessnas. The reason for the issuance of this AD was that there had been several incidents of interruption of fuel flow to the engine leading to the loss of engine power. These incidents were caused by the fuel vent underneath the left wing icing over and preventing the venting of the fuel tank. Rather than require every aircraft to be modified with a new vent system that included anti-ice vents, the FAA felt that the installation of fuel caps with venting provisions for use as a secondary vent system would be both adequate and cost effective. However the misconception in the field is that these caps provide primary and constant venting for the tank on which they are installed. The vented caps have secondary vents in them that are normally closed and will only open when there is a significant difference in external and internal pressure. In other words these cap tank vents only open when the pressure differential is so great that the tank is in imminent danger of collapse. This makes sense in that the caps are mounted on the top surface of the wing, a low pressure area, and if the tank vents were open all the time both erratic feeding and fuel loss could occur.

Cessna, hearing complaints from owners on uneven fuel feeding, tried several things to improve the situation. With the 182 with long range tanks they extended the vent interconnect lines inside the tanks along the top to the outboard edge of the tanks. This began with long range tanks installed in the 1964 182G, s/n 18255059. The idea was that this would raise the vent interconnect line above the fuel level in all cases except with absolutely full tanks. This idea might have worked fairly well except that about the same time, beginning with s/n 18255786 and on, the engineers made another change to the 182's fuel system. Having suspicions that the problem was related to unequal pressures in the tanks, they made an attempt to equalize pressure through out the system as much as possible by venting the forward fuel feed lines to the vent interconnect line running across the top of the fuselage. What this actually does is permit fuel to move from one tank to the other any time there is different head pressure in the tanks, even if the fuel level in the tank is below the height of the vent interconnect line. What will happen is that the tank with the higher head pressure will push fuel through the forward fuel feed line up to the vent interconnect line, across the top of the cabin and

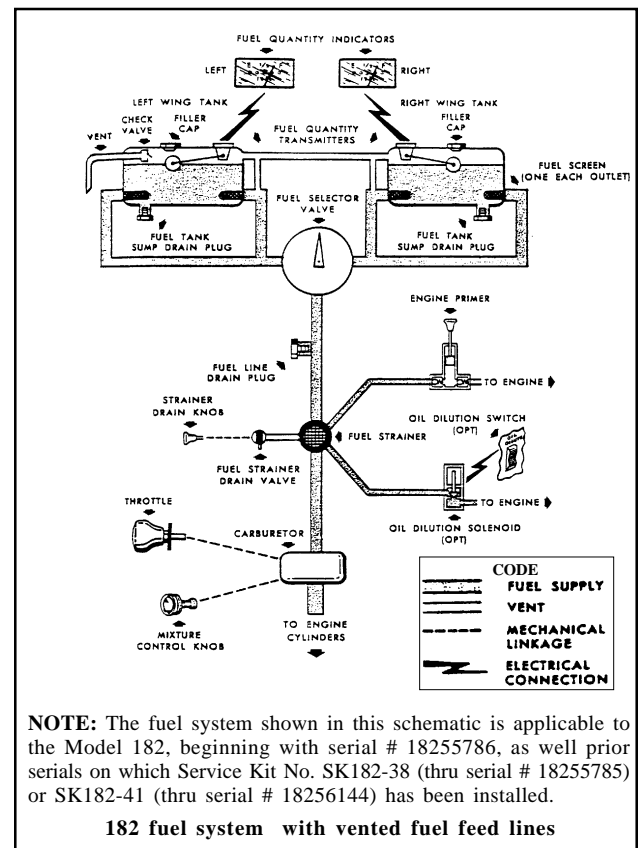

**NOTE:** The fuel system shown in this schematic is applicable to the Model 182, beginning with serial # 18255786, as well prior serials on which Service Kit No. SK182-38 (thru serial # 18255785) or SK182-41 (thru serial # 18256144) has been installed.

down into the vent line for the forward fuel feed line of the other tank (See Drawing). There can be a number of causes of this uneven head pressure which will be discussed a little further on.

Cessna tried a similar idea on the 172 series aircraft begin-



# TECH NOTE

ning in mid 1970, s/n 17258856. In this case however the engineers vented the rear fuel feed lines to the vent interconnect line rather than the front fuel feed lines. The results, unfortunately, were the same. The tank with the higher head pressure, usually the left tank, would push fuel from that tank up the fuel feed line, across the vent interconnect and down the fuel feed line of the opposite tank.

In 1979 Cessna went to integral tanks on the 182 series aircraft. Integral tanks are simply wing bays that are sealed to hold fuel rather than using a bladder as a sort of tank liner. At the same time that the factory changed to integral tanks on the 182, they also installed a second fuel vent underneath the right wing, identical to the one underneath the left wing. This helped the problem somewhat by allowing air into the right tank even if the vent interconnect had fuel in it, but fuel would still move from one tank to the other through the vented fuel feed lines and the vent interconnect line any time there was different head pressure in the tanks.

Again with the 182 series aircraft Cessna made another change. Beginning in 1981 with serial number 18267716 Cessna rerouted the vent line for the forward fuel feed line on the left tank. No longer did it connect with the vent interconnect line, rather the forward fuel feed line was vented by a line that came from high in the left tank itself. By isolating one of the forward fuel feed lines from the vent interconnect line the passing of fuel from one tank to the other when the fuel level was below the vent interconnect line was stopped. The service manual describes vent position adjustment procedures for evening out fuel flows.

While the design of the fuel system itself is the major cause of uneven fuel feeding, there are a number of items related to maintenance and inspection that if not correct can make the problem worse.

## Vent Tube Problems

The position of the vent tube behind the left lift strut is critical to allowing the fuel system to operate at optimum

performance. The idea is that the vent tube 'hides' behind the lift strut to gain some ice protection and has just a small area protruding into the ram air. The positioning of this vent is so critical that Cessna calls out the dimension in hundredths of an inch. It is possible to make some minor adjustments on both the single vent and dual vent aircraft. Keeping in mind that the tank with the greatest head pressure will

feed the fastest, if you want to reduce the head pressure in that tank move the "L" shaped vent tube, which is held in place by an Adel clamp that is accessible through an inspection cover near the vent tube, up and in which will place it more behind the lift strut and reduce the amount of ram air the tank receives. If you wish to increase the head pressure move the vent tube down and out. A couple of cautions in playing around with vent tube location away from the setting specified in the service manual; First make sure that you have looked at all other possible problem areas. Second, make very minor adjustments and check the results rather than making major adjustments. Studies made while STCs for engine upgrades and engine

analyzers were being certified, have shown that it is possible to get vent pressure so low that fuel flow could be questionable, particularly on 180 HP conversions on 172s.

There can also be a problem caused by the lift strut fairing that is positioned in front of the "L" shaped vent tube. Air flow along the bottom surface of the wing can enter this fairing where it mates to the wing and come out the fairing right in front of the vent tube. This high pressure, disturbed air burbling at the entry to the vent tube can have a very significant effect on venting pressures. To prevent this Cessna calls out for installing a seal at the bottom of the fairing on the inside to prevent air leakage in front of the vent. A nice little Saturday morning project for an owner is to drop the fairing down the strut, look inside to see if the seal is present and in good condition and if not replace it with some simple screen door rubber seal available about anywhere.

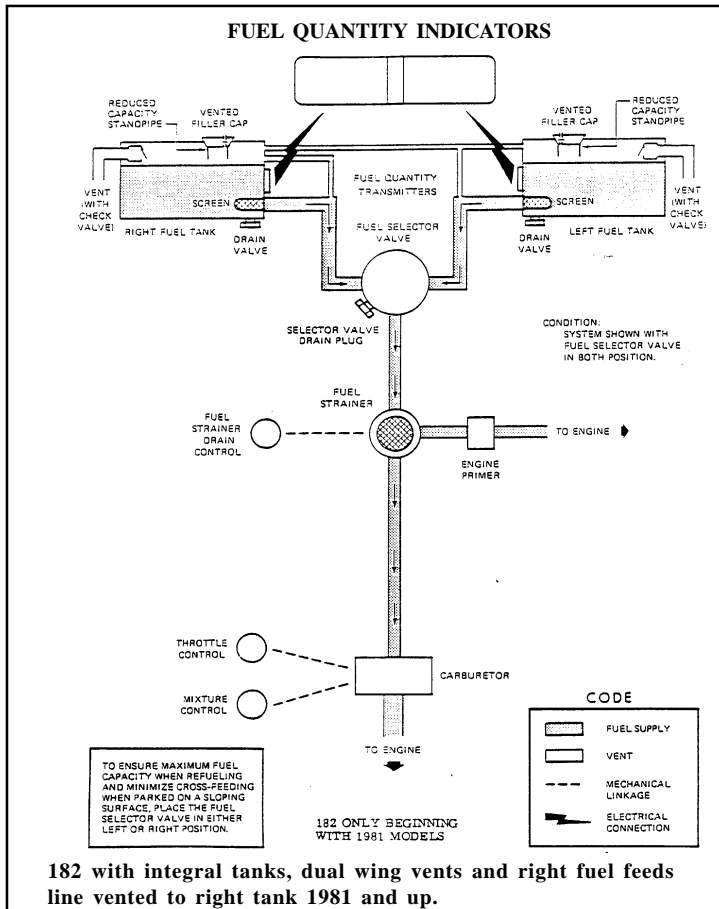



# TECH NOTE

Vent lines can be checked for blockage by gently blowing into them with the fuel caps removed from the aircraft.

## Fuel Caps

The fuel caps sit on top of the wing which is a low pressure area in flight. A fuel tank with a cap which does not seal tight will have a lower head pressure in the tank than a tank with a good sealing cap. This will lead to uneven fuel feeding. This used to be a big problem on the 182s with the flush style fuel caps with the pull up handles, but fortunately most of those caps have been replaced with the umbrella cap style. As a side note to this subject, any operator who is continuing to use flush style fuel caps on a Cessna aircraft with bladder fuel tanks is both a fool and a person who will knowingly jeopardize lives. The combination of the flush style fuel caps that are prone to leak and the fuel bladders that can develop wrinkles that will keep contamination from getting to the sump drain is deadly. All these flush style caps should be changed to either the Cessna umbrella caps available through any Cessna dealer or the Monarch Development caps available from Monarch Development, P.O. Box 419, Oakland, OR 97462 or 541/459-2056, FAX 541/459-1765. Monarch Development also has an STCd rigid fuel tank, which replaces the bladder tanks and has no wrinkles to trap water.

There is a simple test that can be performed to test for air leakage at the caps. Attach a piece of hose to the vent tube underneath the left wing and have someone blow into it. While this person is blowing in the vent line go up by the fuel caps and listen for air escaping. A spray bottle with soapy water can be used as well provided that care is taken not to get any significant contamination in the tank. If testing an aircraft with vent tubes under both wings, one vent tube should be capped off for this test. Testing for fuel cap leakage is covered by Cessna service bulletin SE82-34. Any air leakage at the fuel caps should be corrected to eliminate this as a cause of uneven fuel flow.

## Aircraft Out Of Rig

If your aircraft is out of rig, that is will not fly in a straight line at normal cruise speed without rudder or aileron input, this will cause fuel in one tank to be pushed towards the fuel pickup point with more force than fuel from the other tank, thus creating a greater fuel tank head pressure in one tank leading to uneven fuel flow.

To check for this condition, establish the aircraft in cruise

flight, center the ailerons and rudder and look for a tendency to pull one way or the other. Then compensate for this pull using rudder and aileron as necessary and look at the ball on the turn and bank or the turn coordinator. If control input is required to keep the aircraft straight and level or if the ball is out of center when the aircraft is straight and level, then the aircraft is either out of rig or bent. Details on rigging Cessna single engine aircraft are contained in the Cessna Pilots Association's series of magazine articles titled 'Rigging -

The Key To Speed'. Reprints are available to CPA members.

Some Cessnas are designed with offsets in the engine mounts, vertical stabilizer and rudder to compensate for engine torque and airflow from the propeller, "P" factor. This compensation is de-

signed to give straight flight at normal cruise speed and configuration. Aircraft that are normally flown in other situations, such as in training, surveillance work, fish spotting and pipeline patrol, can expect to experience uneven fuel flow from the tanks as a normal condition. High wing aircraft with gravity feed fuel systems, such as most single engine Cessna aircraft, are more prone to this uneven fuel flow than low wing aircraft due to the gravity feed fuel system in the high wings, whereas the low wing aircraft have fuel pumps either pulling or pushing the fuel from the tanks.

## Fuel Line Restrictions

Fuel line restrictions are rarely the cause of uneven fuel feed, but it can occur. If a fuel line becomes crimped or it's routing changed, then it can offer more resistance to flow than the line from the other tank. If the aircraft involved has a fuel selector with a 'Left' and 'Right' position as well as a 'Both' position this condition can be checked for by turning the fuel off, disconnecting the fuel line at the fuel strainer, then flowing fuel from each tank for an equal period of time. If the amounts of fuel are approximately the same for both positions, the lines aren't restricted. On aircraft that only have a 'BOTH' position then this test will have to be performed by disconnecting the lines at the selector valve. If this is the case it would be better to have the aircraft empty of fuel while the lines are disconnected as there is no way to shut off the fuel down the feed lines. After the lines are disconnected and the test set up, sufficient quantity of fuel can be put in each tank to run the test.

Occasionally a port on the fuel selector can become re-

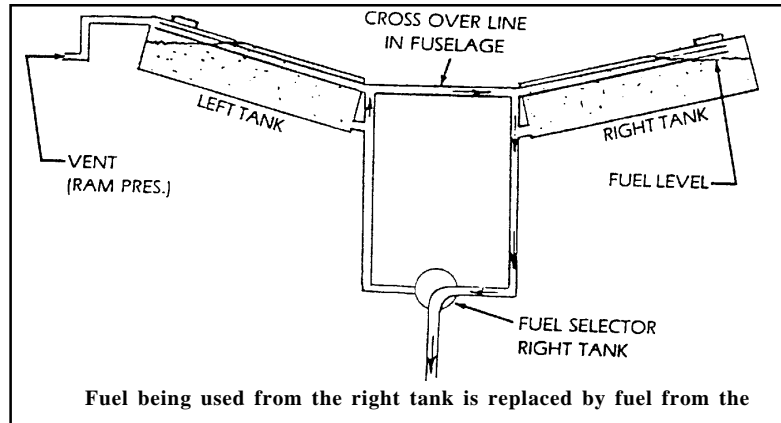



# TECH NOTE

stricted by debris or gum deposits. There are also a few reports of misalignment of the fuel ports occurring on aircraft where the selector valve has had a lot of use or become worn. Inspection of the fuel selector valve ports will reveal if these situations exist.

## Summary

It is important to understand the fuel system, make ad-

justments and corrections where necessary and then be observant of it's operation including refueling. On single engine Cessna aircraft with the single primary vent underneath the left wing certain realities have to be faced, while uneven fuel feed can be minimized to some extent by proper maintenance and adjustment, it can never be totally eliminated without some major modifications to the fuel system.

